

PowerLogic ION7400 series



PowerLogic ION7400

Utility feeder metering

Technical data sheet



optimizer

ION7400 Utility Feeder Meter

Functions and characteristics



PowerLogic ION7400 meter showing active alarms.

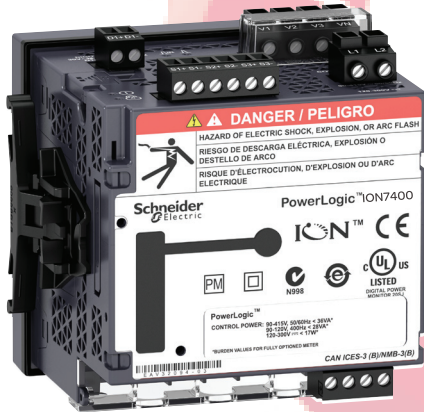

PowerLogic ION7400 meter - rear view.

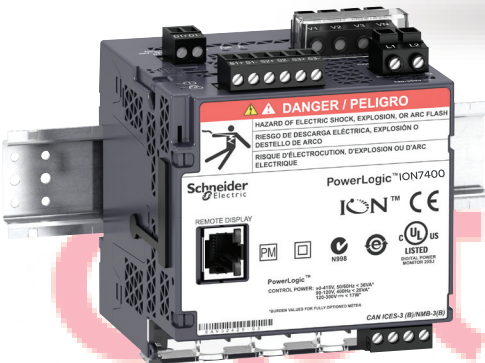

PowerLogic ION7400 DIN rail mounted meter.

The PowerLogic ION7400 utility feeder meter is a highly accurate, extremely reliable power and energy meter with unmatched flexibility and usability. The meter combines accurate 3-phase energy and power measurements with data logging, power quality analysis, alarming and I/O capabilities not typically available in such a compact meter.

The panel or DIN mounted ION7400 meter is flexible enough to fit into a utility's existing billing or SCADA system, providing industry leading cost management (Class 0.2) and network management (Class S PQ) data. It is compliant with stringent international standards that guarantee their metering accuracy and power quality measurements. Ideal for installations that are responsible for maintaining the operation and profitability of a facility.

Applications and benefits

- Maximize profits by providing the highest output possible with the least amount of risk to availability.
- Optimize availability and reliability of electrical systems and equipment.
- Monitor power quality (PQ) for compliance and to prevent problems.
- Meters fully supported by StruxureWare Power Monitoring Expert and PowerSCADA Expert Software.

Main characteristics

- Precision metering:
 - IEC 61557-12 PMD Sx K70 3000m 0.2 (performance measuring and monitoring functions).
 - Class 0.2S accuracy IEC 62053-22, ANSI C12.20 Class 0.2 (active energy).
 - Industry leading Class 0.5S accuracy for reactive energy (IEC 62053-24).
 - Cycle-by-cycle RMS measurements updated every 1/2 cycle.
 - Full 'multi-utility' WAGES metering support.
 - Net metering.
 - Anti-tamper protection seals.
 - Test mode.
- PQ compliance reporting and basic PQ analysis.
 - Monitors and logs parameters in support of international PQ standards,
 - IEC 61000-4-30 Class S
 - IEC 61000-4-15 Flicker
 - IEC 62586
 - EN 50160

Generates onboard PQ compliance reports accessible via onboard web pages:

- Basic event summary and pass/fail reports, such as EN 50160 for power frequency, supply voltage magnitude, supply voltage dips, short and long interruptions, temporary over voltages, voltage unbalance and harmonic voltage.
- ITIC (CBEMA) and SEMI curves, with alarm categorization to support further analyses.
- Basic meter provides EN 50160 but can be configured to provide IEEE 519.
- Harmonic analysis:
 - THD on voltage and current, per phase, min/max, custom alarming.
 - Individual harmonic magnitudes and angles on voltage and current, up to the 63rd harmonic.
- High resolution waveform capture: triggered manually or by alarm, captured waveforms available directly from the meter via FTP in a COMTRADE format.
- Disturbance detection and capture: sag/swell on any current and voltage channel, alarm on disturbance event, waveform capture with per-event information.
- Patented disturbance direction detection: provides indication of the captured disturbance occurring upstream or downstream of the meter; timestamped results provided in the event log, with degree of certainty of disturbance direction.
- Used with StruxureWare Power Monitoring Expert software, provides detailed PQ reporting across entire network:
 - EN 50160 report.
 - IEC 61000-4-30 report.
 - PQ compliance summary.
 - ISO 50001.
 - Display of waveforms and PQ data from all connected meters.

ION7400 Utility Feeder Meter

Functions and characteristics (cont.)

PB115153



PowerLogic ION7400 with Harmonics display.



PowerLogic remote display.

PB113671

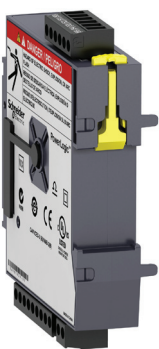

PowerLogic I/O module.



PowerLogic ION7400 meter with remote display.

- Onboard data and event logging.
 - 512MB of standard non-volatile memory. 10 MB of standard non-volatile memory dedicated to capture billing data, events, and waveforms.
 - No data gaps due to network outages or server downtime.
 - Min/Max log for standard values.
 - 50 user-definable data logs, recording up to 16 parameters on a cycle-by-cycle or other user definable interval.
 - Continuous logging or 'snapshot' triggered by setpoint and stopped after defined duration.
 - Trend energy, demand and other measured parameters.
 - Forecasting via web pages: average, minimum and maximum for the next four hours and next four days.
 - Time-of-use in conjunction with StruxureWare software.
 - Event log: alarm conditions, metering configuration changes, and power outages, timestamped to 1 millisecond.

- Alarming and control.
 - 50+ definable alarms to log critical event data, trigger waveform recording, or perform control function.
 - Trigger on any condition, with cycle-by-cycle and 1-second response time.
 - Combine alarms using Boolean logic and to create alarm levels.
 - Alarm notification via email text message.
 - In conjunction with StruxureWare Power Monitoring Expert, software alarms and alarm frequency are categorized and trended for easy evaluation of worsening/improving conditions.

- Excellent quality: ISO 9001 and ISO 14000 certified manufacturing.

Usability

- Easy installation and setup.
 - Panel and DIN mounting options, remote display option.
 - Pluggable connectors.
 - Free setup application simplifies meter configuration.
- Front panel.
 - Easy to read colour graphic display.
 - Simple, intuitive menu navigation with multi-language (8) support.
 - Optical port
 - 2 energy pulsing LEDs.
 - Alt/Norm screens.
- Flexible remote communications.
 - Multiple simultaneously operating communication ports and protocols allow interfacing with other automation systems; (e.g. waveforms, alarms, billing data, etc.) can be uploaded for viewing/analysis while other systems access real-time information.
 - Supports Modbus, ION, DNP3, IEC 61850.
 - Dual port Ethernet: 10/100base-TX; daisy-chaining capability removes need for additional switches.
 - Create redundant network loop using Rapid Spanning Tree Protocol (RSTP) and managed Ethernet switches.
 - Customize TCP/IP port numbers enable/disable individual ports.
 - RS-485 2-wire connection, up to 115200 baud, Modbus RTU and ION protocols, DNP3 is also supported via RS-485.
 - Ethernet to serial gateway with Modbus Master functionality, connecting to 31 downstream serial Modbus devices. Also supports Modbus Mastering over TCP/IP (Ethernet) network.
 - Full function web server with factory and customizable pages to access real-time and PQ compliance data.
 - Push historical data via email.
 - Advanced security: Up to 16 configurable user accounts.
- Time synchronization via:
 - GPS clock (RS485) or IRIG-B (digital input) to +/- 1 millisecond.
 - Also supports Network Time Protocol (NTP/SNTP) and time set function from StruxureWare software server.

ION7400 Utility Feeder Meter

Functions and characteristics (cont.)

PD115159



PowerLogic ION7400 series meter with phasor display.

Adaptability

- ION™ frameworks allow customizable, scalable applications, object-oriented programming, compartmentalizes functions, and increases flexibility and adaptability.
- Applications include: access and aggregate data from Modbus devices on serial port or across the network (Modbus TCP/IP), logging and/or processing data by totalizing, unit conversion or other calculations, applying complex logic for alarming or control operations, data visualization via web pages.

Standard meter I/O

- 3 digital status/counter inputs.
- 1 KY (form A) energy pulse output for interfacing with other systems.

Modular I/O options

- Optional expansion modules (up to 4 per meter) add digital/analogue I/O.

Option modules include:

- Digital module.
 - 6 digital status/counter inputs.
 - 2 Form C relay outputs, 250V, 8A.
- Analogue module.
 - 4 analogue inputs (4-20mA; 0-30V).
 - 2 analogue outputs (4-20mA; 0-10V) for interfacing with building management sensors and systems.

Standards

- IEC 61000-4-30
- IEC 61000-4-7
- IEC 61000-4-15
- IEC 61326-1
- ANSI C12.20
- IEC 62052-11
- IEC 62053-22
- CLC/TR50579

Languages supported

English, French, Spanish, Chinese, Italian, German, Russian, Portuguese

Reference numbers	
Meter	Description
METSEION7400	ION7400 Panel mount meter (integrated display with optical port and 2 energy pulse LEDs)
METSEION7403	DIN rail mount - utility meter base
Accessories	Description
METSEPM89RD96	Remote display, 3 metre cable, mounting hardware for 30mm hole (nut & centering pin), mounting hardware for DIN96 cutout (92x92mm) adapter plate
METSEPM89M2600	Digital I/O module (6 digital inputs & 2 relay outputs)
METSEPM89M0024	Analogue I/O module (4 analogue inputs & 2 analogue outputs)
METSECB10	Display Cable, 10 metres

ION7400 Utility Feeder Meter

Functions and characteristics (cont.)

PB113696



PowerLogic™ ION7400 bottom view DIN mounting.

Features guide		ION7400
General		
Use on LV and MV systems		■
Current accuracy (5A Nominal)		0.1 % reading
Voltage accuracy (90-690 V AC L-L, 50, 60, 400 Hz)		0.1 % reading
Active energy accuracy		0.2 %
Number of samples/cycle or sample frequency		256
Instantaneous rms values		
Current, voltage, frequency		■
Active, reactive, apparent power		Total and per phase
Power factor		Total and per phase
Current measurement range (autoranging)		0.05 - 10A
Energy values		
Active, reactive, apparent energy		■
Settable accumulation modes		■
Demand values		
Current		Present and max. values
Active, reactive, apparent power		Present and max. values
Predicted active, reactive, apparent power		■
Synchronisation of the measurement window		■
Setting of calculation mode		Block, sliding
Power quality measurements		
Harmonic distortion		Current and voltage
Individual harmonics		Via front panel and web page
		Via StruxureWare software
Waveform capture		■
Detection of voltage swells and sags		■
Flicker		■
Fast acquisition		1/2 cycle data
EN 50160 compliance checking		■
Customizable data outputs (using logic and math functions)		■
Data recording		
Min/max of instantaneous values		■
Data logs		■
Event logs		■
Trending/forecasting		■
SER (Sequence of event recording)		■
Time stamping		■
GPS synchronisation (+/- 1 ms)		■
Memory (in Mbytes)		512 (10 MB for Frameworks)
Display and I/O		
Front panel display 89 mm (3.5 in.) TFT		■
Wiring self-test		■
Pulse output		1
Digital		6 In / 2 Out
Analogue		4 In / 2 Out
Digital or analogue outputs (max, including pulse output)		1 digital 8 relay 8 analogue
Communication		
RS 485 port		1
10/100BaseTX		2
Serial port (Modbus, ION, DNP3)		■
Ethernet port (Modbus/TCP, ION TCP, DNP3 TCP, IEC 61850 ⁽²⁾)		■
ANSI C12.19 Optical port		■

All the communications ports may be used simultaneously

ION7400 meter parts descriptions

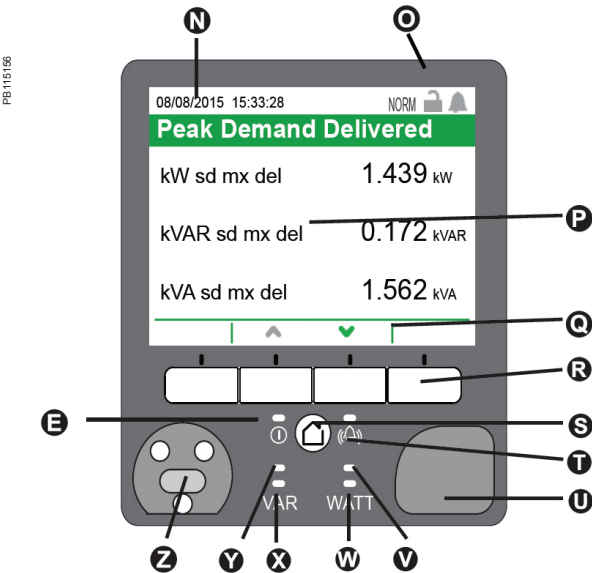
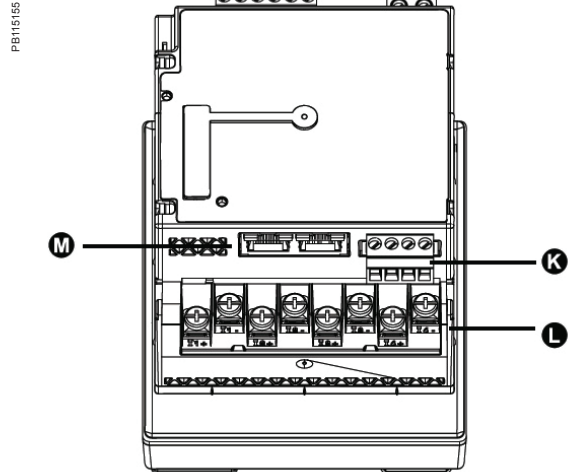
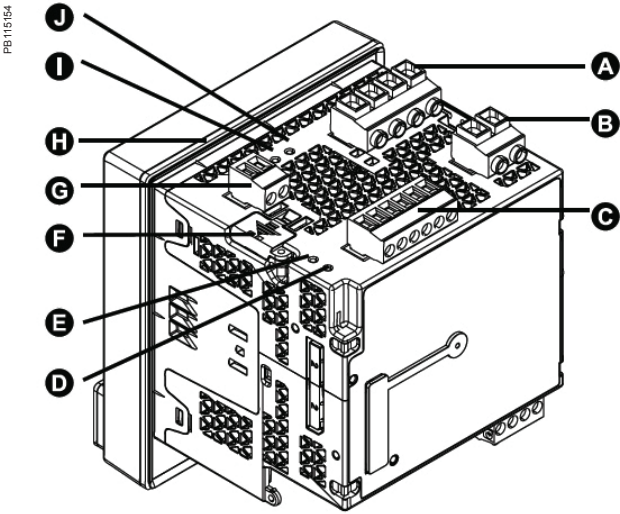

- A Voltage inputs
- B Control power
- C Digital inputs
- D Revenue lock LED
- E Status LED (2)
- F Revenue lock switch
- G Digital output
- H Sealing gasket
- I Infrared energy pulsing LED
- J Energy pulsing LED
- K RS-485
- L Current inputs
- M Ethernet (2)
- N Date/time
- O Indicator icons
- | | | |
|---------------|---------|-------|
| NORM/ALT Mode | Revenue | Alarm |
|---------------|---------|-------|
- P Display
- Q Navigation icons
- | | | | | | | | |
|--|--------|--|--------|--|------|--|------|
| | Select | | Cancel | | Edit | | More |
|--|--------|--|--------|--|------|--|------|
- R Navigation buttons
- S Home button
- T Alarm LED
- U USB ports cover
- V Watt energy pulsing LED
- W Watt infrared energy pulsing LED
- X VAR infrared energy pulsing LED
- Y VAR energy pulsing LED
- Z Optical port



ION7400 Utility Feeder Meter

Dimensions and connection

ION7400 meter dimensions

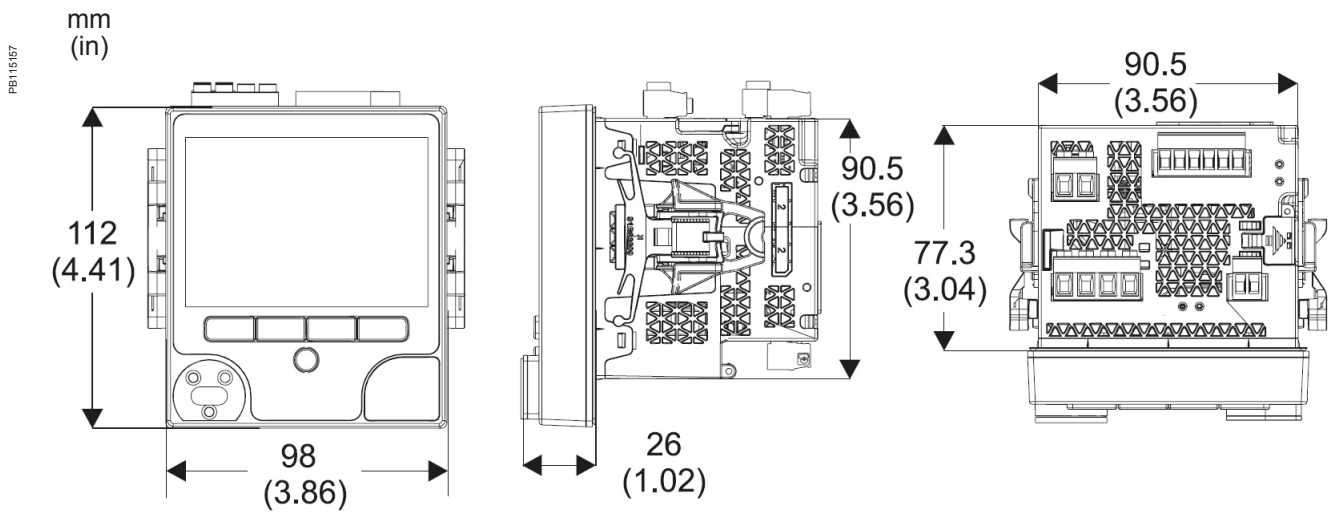

ION7400 panel cut-out dimensions

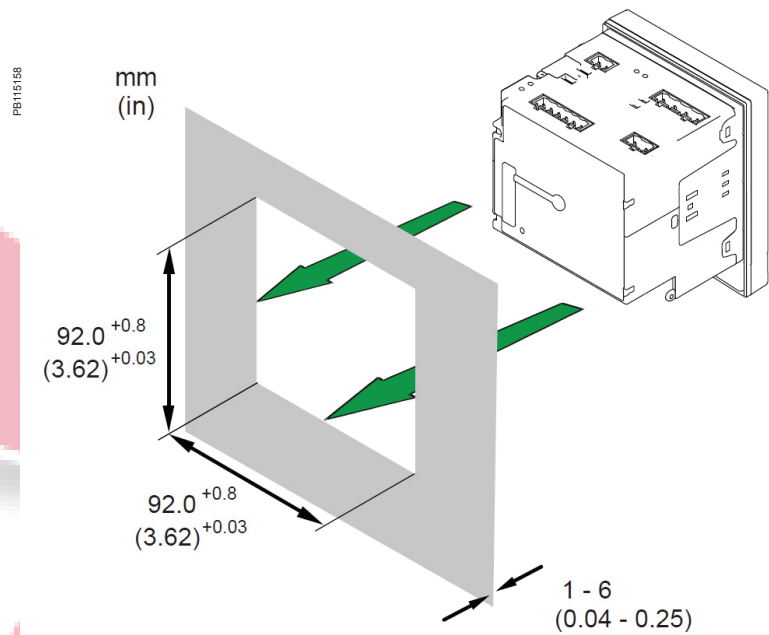

optimizer

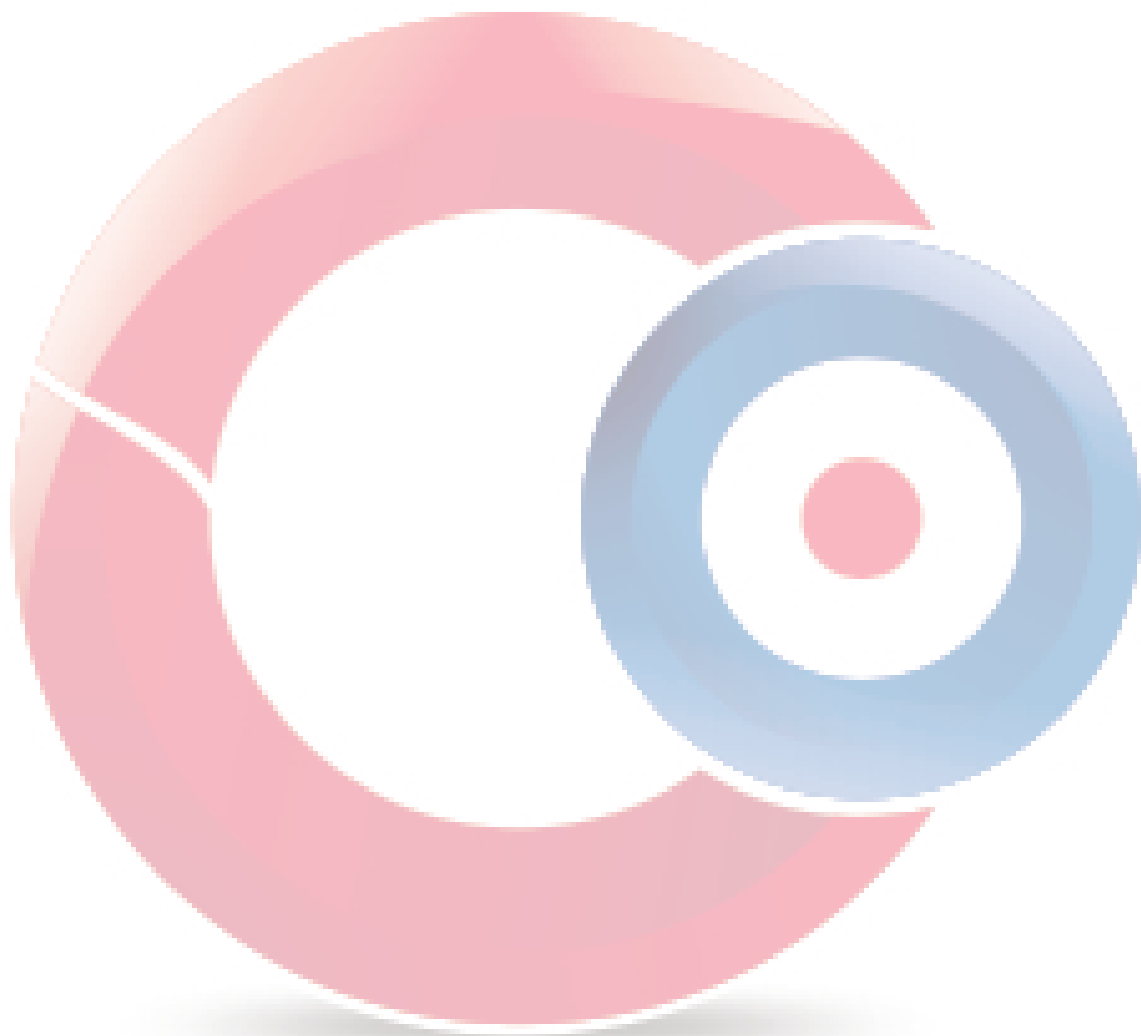

optimizer

Schneider Electric Industries SAS
35, Rue Joseph Monier,
CS 30323
F - 92506 Rueil Malmaison Cedex

RCS Nanterre 954 503 439
Capital social 896 313 776
www.schneider-electric.com

As standards, specifications and designs develop from time to time, please ask for confirmation of the information given in this document.

Design: Schneider Electric
Photos: Schneider Electric



MACHINE
INTEGRATOR
PARTNER

PowerLogic ION7400 | Funciones y características

Solo el personal autorizado puede instalar, revisar, manipular y realizar el mantenimiento del equipo electrónico.

Para obtener ayuda adicional póngase en contacto con nosotros en:

- www.optimizar.com.ar
- info@optimizar.com.ar